

TECHNICAL CHARACTERISTICS

SALOETB

# Alo

## Chair

A steel structure that surrounds a varnished, upholstered or laminated wooden shell. Two different materials meet and respect each other, leaving space between them that makes the piece lightweight, endowing it with an elegant and simple personality.

DESIGNED BY GABRIEL TEIXIDÓ



**ondarreta**

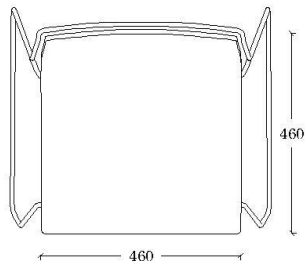
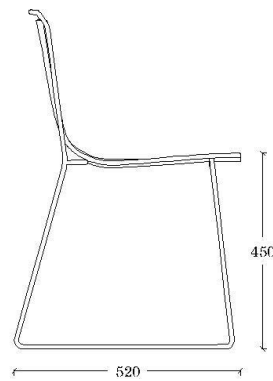
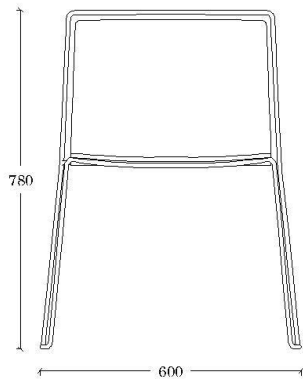

### DIMENSIONS

60 cm x 52 cm x 78 cm x 45 cm  
(23.6" x 20.5" x 30.7" x 17.7"  
[width x depth x height x seat  
height])

### WEIGHT

6,7 kg (14.7 lb)

### PACKAGING

Two chairs per box.  
Box dimensions:

71 cm x 66 cm x 99 cm  
(28" x 26" x 39")

### CERTIFICATION

Product tested under the European  
standard EN 161399:2013, category  
of general use L1.

**ondarreta**

### ACCESORIES

Linking pieces (included)

Option Felt glides

Trolley

### OPTION

Outdoor

### STACKABILITY

8 units

### ORIGEN

100% Made in Europe

### DISEÑO

Gabriel Teixidó



## **COMPONENTS**

### **FRAME**

#### **Material**

12 mm (0.5") diameter cold laminated E-220 quality (EN-10305 Normative) steel rod.

Tensile Strength > 310 N/mm<sup>2</sup> (44,960 psi);

Elastic Limit > 220 N/mm<sup>2</sup> (31,900 psi); Elongation > 23%

#### **Finish**

Colour Epoxy

### **SEAT**

#### **Beech**

Beech plywood board seat, 10 mm (0.4") thick. It's made of especially treated sheets, glued, pressed and CNC mechanized.

#### **Fabrics**

Upholstered with exclusive method to fix the fabric to the seat and keep the shape of the chair. 10 mm (0.4") thick medium density polyether stuffing foam.

#### **Beech + fabric**

Beech plywood seat assembled to board shell.

Upholstered at the seat and stained the shell (4 and 7 mm thick) (0.16" and 0.27"). Medium density polyether stuffing foam.

#### **Laminate**

High pressure laminate glued and pressed in high temperatures on seat.

#### **Technical Characteristics:**

Urea-formol glue: low formaldehyde emission (E1 European Normative)

The wood has the PEFC certificate.

#### **Finish**

Texturized Mat, upholstered or seat pad.

## **METAL FINISHES**

### **EPOXYS**

Powder covering formulated with polyester resins, with good both mechanical and chemical properties, outdoor maximum resistance and noxious compounds free. Electrostatic application and oven cured at 200°C (392°F).

#### **Technical Characteristics:**

Thickness (ISO 2360): between 60 and 90 µm.

Adherence (ISO 2409): Grade: 0 (maximum adherence)

## **COM REQUIREMENTS**

Full Fabric: 80 cm (31.5")

Fabric Seat: 45 cm (17.7")